

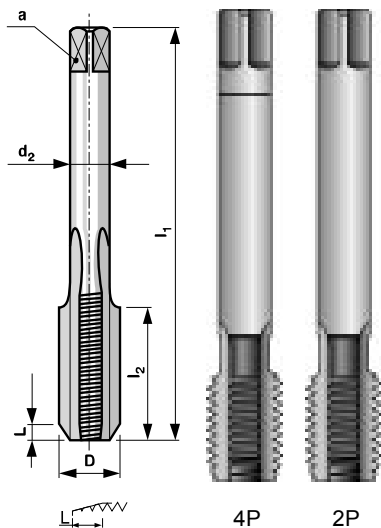

Метчици ръчни, ситна стъпка, комплект 2 броя, DIN 2181, HSS

Метрична резба MF

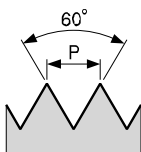
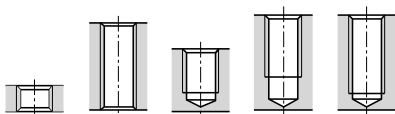

D	P	l ₁	l ₂	d ₂	a	препоръчителен размер на свредлото, mm	Z
							брой пера
M 2,5	0,35	40	9	2,8	2,1	2,15	2
M 3	0,35	40	9	3,5	2,7	2,65	2
M 3,5	0,35	45	10	4,0	3,0	3,15	2
M 4	0,5	45	10	4,5	3,4	3,50	2
M 4,5	0,5	50	12	6,0	4,9	4,0	2
M 5	0,5	50	12	6,0	4,9	4,5	2
M 5,5	0,5	50	12	6,0	4,9	5,0	2
M 6	0,75	50	14	6,0	4,9	5,2	2
M 7	0,75	50	14	6,0	4,9	6,2	2
M 8	1	56	22	6,0	4,9	7,0	2
M 8	0,75	50	19	6,0	4,9	7,2	2
M 9	1	63	22	7,0	5,5	8,0	2
M 9	0,75	56	19	7,0	5,5	8,2	2
M 10	1,25	70	24	7,0	5,5	8,8	2
M 10	1	63	20	7,0	5,5	9,0	2
M 10	0,75	63	20	7,0	5,5	9,2	2
M 11	1	63	20	8,0	6,2	10,0	2
M 11	0,75	63	20	8,0	6,2	10,2	2
M 12	1,5	70	22	9,0	7,0	10,5	2
M 12	1,25	70	22	9,0	7,0	10,8	2
M 12	1	70	22	9,0	7,0	11,0	2
M 14	1,5	70	22	11	9,0	12,5	2
M 14	1,25	70	22	11	9,0	12,8	2
M 14	1	70	22	11	9,0	13,0	2

Метрична резба MF

D	P	l₁	l₂	d₂	a	препоръчителен размер на свредлото, мм	Z
мм	мм	мм	мм	мм	мм		брой пера
M 15	1	70	22	12	9,0	14,0	2
M 16	1,5	70	22	12	9,0	14,5	2
M 16	1	70	22	12	9,0	15,0	2
M 17	1	70	22	12	9,0	16,0	2
M 18	1,5	80	22	14	11,0	16,5	2
M 18	1	80	22	14	11,0	17,0	2
M 20	1,5	80	22	16	12,0	18,5	2
M 20	1	80	22	16	12,0	19,0	2
M 22	1,5	80	22	18	14,5	20,5	2
M 22	1	80	22	18	14,5	21,0	2
M 24	2	90	22	18	14,5	22,0	2
M 24	1,5	90	22	18	14,5	22,5	2
M 24	1	90	22	18	14,5	23,0	2
M 25	1,5	90	22	18	14,5	23,5	2
M 26	1,5	90	22	18	14,5	24,5	2
M 27	2	90	22	20	16	25	2
M 27	1,5	90	22	20	16	25,5	2
M 27	1	90	22	20	16	26	2
M 28	2	90	22	20	16	26	2
M 28	1,5	90	22	20	16	26,5	2
M 30	2	90	22	22	18	28	2
M 30	1,5	90	22	22	18	28,5	2
M 30	1	90	22	22	18	29	2