

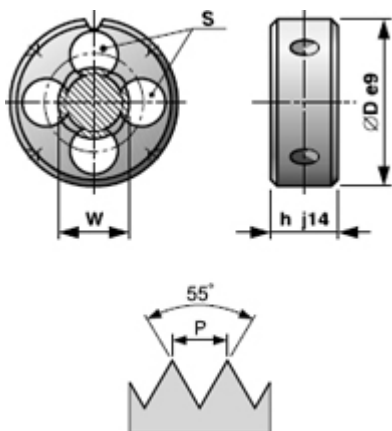

Плашки, DIN 223 / EN 22 568, витвортова резба BSW (W)

Резба W

	z/1"	P	D	h	S	препоръчителен размер на свредлото, мм
W 1/16"	60	0,423	16	5	3	1,5
W 3/32"	48	0,529	16	5	3	2,3
W 1/8"	40	0,635	20	5	3	3,1
W 5/32"	32	0,794	20	5	3	3,9
W 3/16"	24	1,058	20	7	3	4,7
W 7/32"	24	1,058	20	7	4	5,5
W 1/4"	20	1,270	20	7	4	6,3
W 5/16"	18	1,411	25	9	4	7,9
W 3/8"	16	1,588	30	11	4	9,5
W 7/16"	14	1,814	30	11	5	11,1
W 1/2"	12	2,117	38	14	4	12,7
W 9/16"	12	2,117	38	14	5	14,2
W 5/8"	11	2,309	45	18	5	15,8
W 3/4"	10	2,540	45	18	5	19,0
W 7/8"	9	2,822	55	22	5	22,2
W 1"	8	3,175	55	22	6	25,4
W 1 1/8"	7	3,629	65	25	6	28,5
W 1 1/4"	7	3,629	65	25	7	31,7
W 1 3/8"	6	4,233	65	25	7	34,9
W 1 1/2"	6	4,233	75	30	7	38,1
W 1 5/8"	5	5,080	75	30	8	41,2
W 1 3/4"	5	5,080	90	36	7	44,4
W 1 7/8"	4,5	5,644	90	36	7	47,6
W 2"	4,5	5,644	90	36	8	50,8