

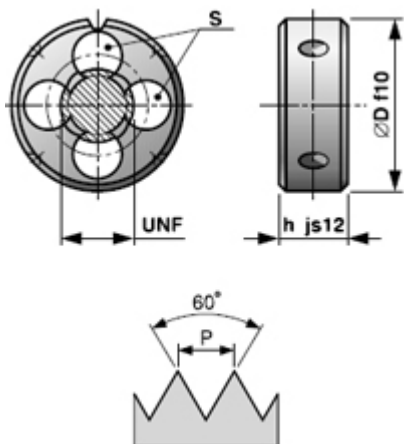

Плашки, DIN 223 / EN 22 568,
унифицирана ситна резба UNF

Резба UNF



	z/1"	P	D	h	S	препоръчителен размер на свредлото, mm
4	48	0,577	20	5	3	2,8
5	44	0,577	20	5	3	3,1
6	40	0,635	20	7	3	3,4
8	36	0,706	20	7	3	4,1
10	32	0,794	20	7	4	4,7
12	28	0,907	20	7	4	5,4
1/4	28	0,907	20	7	4	6,2
5/16	24	1,058	25	9	4	7,8
3/8	24	1,058	30	11	4	9,4
7/16	20	1,270	30	11	5	10,95
1/2	20	1,270	38	10	5	12,5
9/16	18	1,411	38	10	5	14,1
5/8	18	1,411	45	14	5	15,7
3/4	16	1,588	45	14	6	18,9
7/8	14	1,814	55	16	5	22,05
1	12	2,117	55	16	6	25,2