

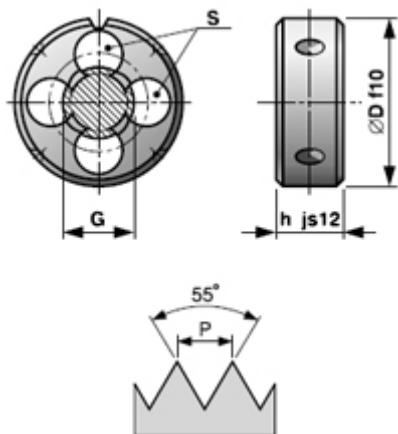

Плашки, DIN 5158 / EN 24 231,  
тръбна цилиндрична резба G

Резба G



	z/1"	P	D	h	S	препоръчителен размер на свредлото, mm
<b>G 1/16"</b>	28	0,907	25	9	4	7,7
<b>G 1/8"</b>	28	0,907	30	11	4	9,7
<b>G 1/4"</b>	19	1,337	38	10	5	13,1
<b>G 3/8"</b>	19	1,337	45	14	5	16,6
<b>G 1/2"</b>	14	1,814	45	14	6	20,9
<b>G 5/8"</b>	14	1,814	55	16	6	22,9
<b>G 3/4"</b>	14	1,814	55	16	6	26,4
<b>G 7/8"</b>	14	1,814	65	18	6	30,2
<b>G 1"</b>	11	2,309	65	18	8	32,2
<b>G 1 1/8"</b>	11	2,309	75	20	8	38,8
<b>G 1 1/4"</b>	11	2,309	75	20	9	41,9
<b>G 1 3/8"</b>	11	2,309	90	22	8	44,3
<b>G 1 1/2"</b>	11	2,309	90	22	8	47,8
<b>G 1 3/4"</b>	11	2,309	105	22	8	53,7
<b>G 2"</b>	11	2,309	105	22	8	59,6